

SEE MODEL QUESTION PAPER

UG

USN

--	--	--	--	--	--	--	--	--	--	--	--	--	--	--	--	--	--	--	--

21CIV14

First Semester B.E Degree Examination, March- 2022

Engineering Mechanics

Time: 3 hrs.

Max. Marks: 100

Note: Answer any Five full questions, choosing ONE full question from each module.

Q. No.	Questions	Marks
--------	-----------	-------

Module 1

- | | | |
|---|---|----------------|
| 1 | <p>a Explain the Following.</p> <p style="margin-left: 20px;">i) Composition of forces and Resolution of forces</p> <p style="margin-left: 20px;">ii) Moment of a force and Couple</p> <p>b Determine the magnitude, direction and the point of application of the resultant force for the given system of forces as shown in figure.</p> | 8

6 |
|---|---|----------------|

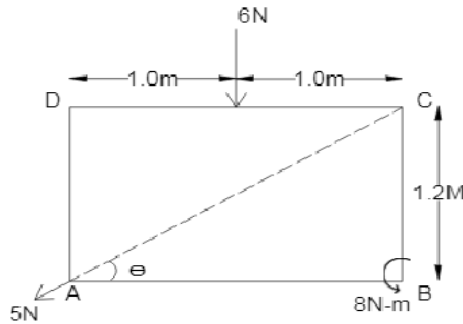

- | | | |
|--|---------------------------------------|---|
| | c State and prove Varignon's theorem. | 6 |
|--|---------------------------------------|---|

OR

- | | | |
|---|---|---|
| 2 | <p>a Forces of 20 kN, 30 kN, 40 kN, 50 kN, and 60 kN act from the vertex 'A' of rectangular hexagon ABCDEF towards other vertices B, C, D, E and F respectively as shown in figure. Determine the magnitude and direction of resultant of forces.</p> | 8 |
|---|---|---|

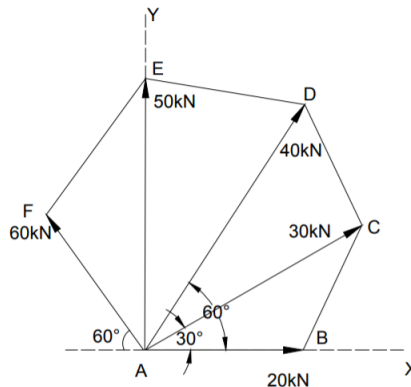

- | | | |
|---|--|---|
| b | <p>A flat plate is subjected to a coplanar system of forces shown in figure. Each square of the inscribed grid is having length of 1.0 m. Determine the resultant with respect to A.</p> | 8 |
|---|--|---|

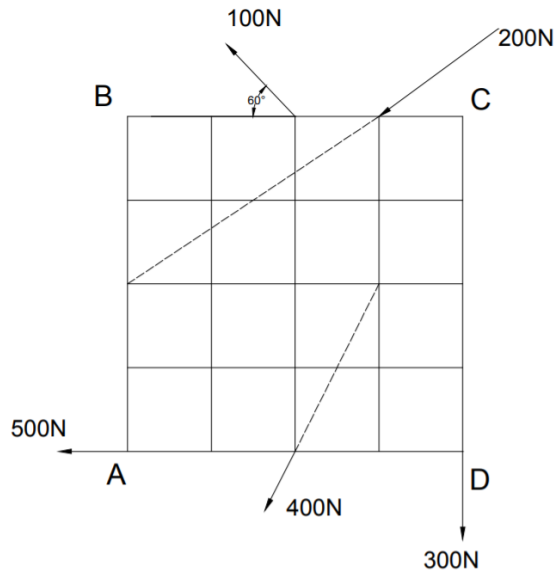

c Explain transmissibility of force. 4

Module – 2

3 a The frictionless pulley 'A' shown in figure. is supported by two bars AB and AC which are hinged at 'B' and 'C' to a vertical wall. The flexible cable DG hinged at 'D', goes over the pulley and supports a load of 20 kN at 'G'. The angles between the various members are shown in the figure. Determine the forces in the bars AB and AC. Neglect the size and weight of the pulley. 10

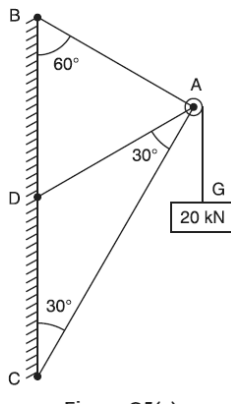

b Determine the reactions at the point of contact for the sphere shown in figure. 6

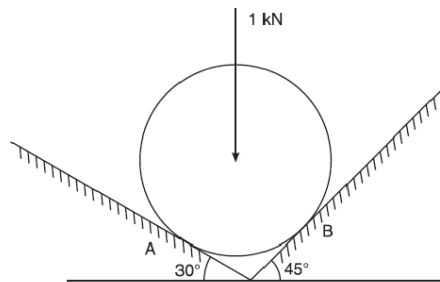

c Explain the types of loading on the beams. 4

OR

4 a Determine the distance x of the load P from the support A , if the reaction R_A is twice as great as reaction R_B . Take $P = 2 \text{ kN}$, $Q = 1 \text{ kN}$ 8

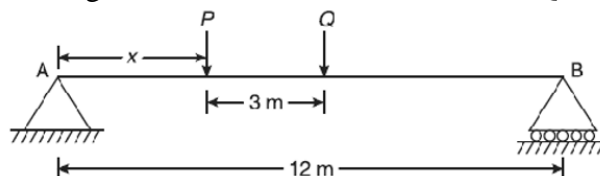

- b With neat sketches, explain various types of supports. 6
- c Find the support reactions R_A and R_B for the beam loaded as shown in figure. 6

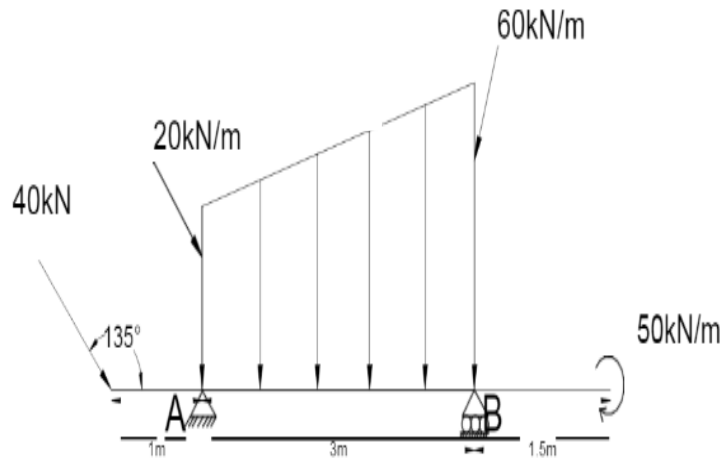

Module – 3

- 5 a Locate the centroid of a given composite area shown in figure. 14

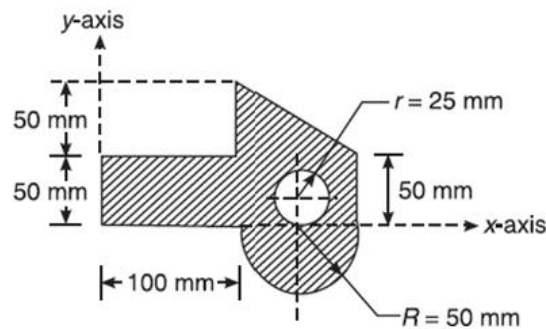

- b Derive the position of centroid of a semi-circular lamina of radius “R”. 06

OR

- 6 a The cross-section of a cast iron beam is shown in Fig. Determine the moment of Inertia about the centroidal axes. 12

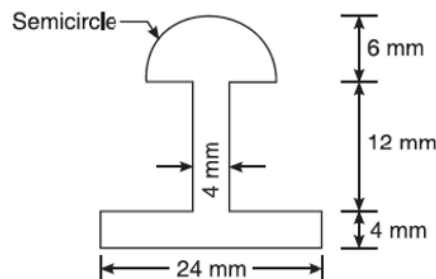

- b Derive an expression for moment of inertia of a semicircle with respect to its diameter line and also w.r.t centroidal axis parallel to diameter line. 08

Module 4

- 7 a What is the value of 'P' in the system shown in Figure, to cause the motion to impend to the right? Assume the pulley is smooth and coefficient of friction between the other contact surfaces is 0.20. 10

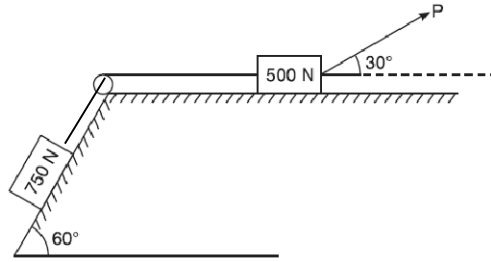

- b A ladder 7 m long weighing 300 N is resting against a wall at an angle of 60° to the horizontal ground. A man weighing 700 N climbs the ladder, at what position does he induce slipping. Take $\mu = 0.25$ for all contact surfaces. 10

OR

- 8 a Explain different types of friction. 4
 b Define the terms: 8
 a. Angle of friction
 b. Angle of Repose
 c. Limiting Friction
 d. Coefficient of friction
 c What should be the value of θ as shown in the figure which will make the motion of 900 N block down the plane to impend? The coefficient of friction for all the contact surfaces is $1/3$. 8

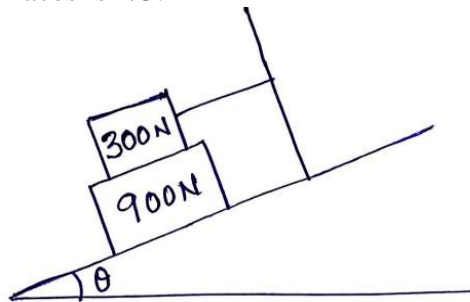

Module 5

- 9 a Explain with neat sketch for projectile motion: 10
 i) Range.
 ii) Time of flight.
 iii) Maximum height.
 iv) Angle of projection.
 v) Projectile.
 b A stone is dropped into a well and a sound of splash is heard after 4 seconds. Find the depth of well if velocity of sound is 320 m/s. 10

OR

- 10 a A burglar's car starts with an acceleration of 2 m/sec^2 . A police vigilant party came after 5 seconds and continued to chase the burglar's car with uniform velocity of 20 m/sec. Find the time taken in which the police van will overtake the car. 10
 b A cricket ball is thrown by a fielder in ground from a height of 3 m at an angle of 40° with horizontal. The velocity with which the ball is thrown is 30 m/sec. The ball hits the wicket at a height of 0.3 m from ground. Determine the distance of fielder from the wicket when the ball is thrown. 10